

Air Pump

HYDRAULIC PA6D SERIES

98 cm³/min.
Double-Acting

Compact, lightweight and portable single-speed pump for driving double-acting cylinders.

- Operate at 3-8 bar shop air pressure at the pump.
- Internal relief valve protects circuit components, air inlet filter protects motor.
- Serviceable pump motor is not a “throw away”, providing economical repair.
- Permanently vented reservoir cap.
- dBA 85 at 700 bar for all PA6 pumps.

PUMPS

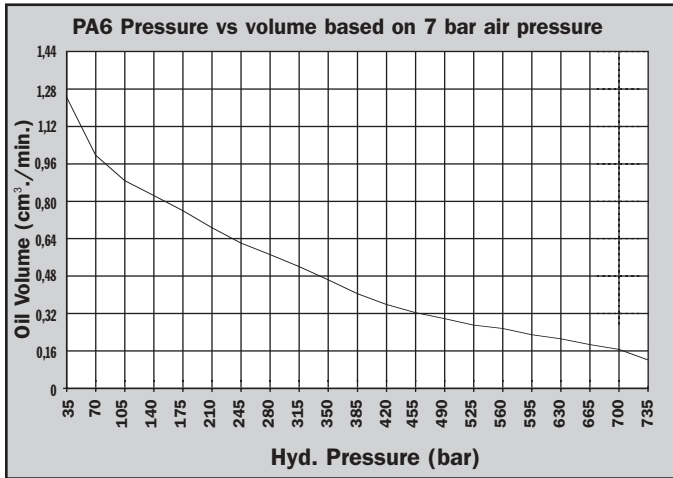

PA6D

700 bar

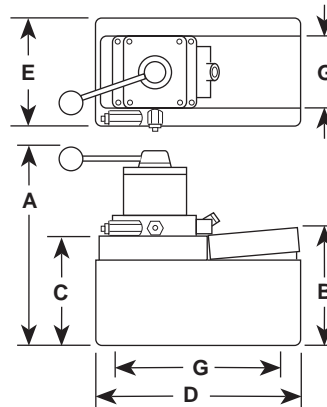

Pump No.	A (mm)	B (mm)	C (mm)	D (mm)	E (mm)	G (mm)
PA6D	264	149	111	241	127	102 x 229
PA6DM	264	149	111	241	127	102 x 229
PA6DM-1	279	146	111	321	187	—
PA6D2	324	203	178	287	235	130 x 181
PA6DM-2	318	197	171	292	241	203 x 254



PA6D pump, DG100 digital pressure gauge and 25 ton cylinder used in a test fixture.

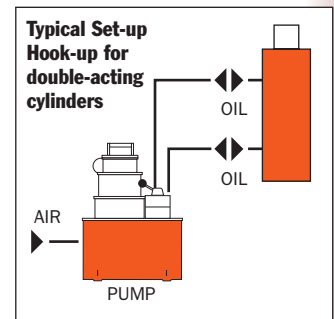

Description	Order No.	Valve No.	Air Supply Req'd (bar)	Reservoir Cap. (l)	Reservoir Usable (l)	Oil Port (in)	Prod. Wt (kg)
Base model pump with high density polyethylene reservoir.	PA6D	9504, 3-way/ 4-way	3 - 8	1,7	1,6	3/8-NPTF	8,3
PA6D, except has metal reservoir.	PA6DM	9504, 3-way/ 4-way	3 - 8	1,7	1,6	3/8-NPTF	9,2
PA6D, except has 3,8 l metal reservoir.	PA6DM-1	9504, 3-way/ 4-way	3 - 8	3,8	3,0	3/8-NPTF	12,7
PA6D, except has 7,6 l, high density polyethylene reservoir.	PA6D2	9504, 3-way/ 4-way	3 - 8	7,6	7,3	3/8-NPTF	13,0
PA6D, except has 9,5 l metal reservoir.	PA6DM-2	9504, 3-way/ 4-way	3 - 8	9,5	9,1	3/8-NPTF	16,4

