

# Push-Pullers®

## HYDRAULIC

17½, 30-50 Ton

The power to make impossible jobs become routine.

BEARING MAINTENANCE

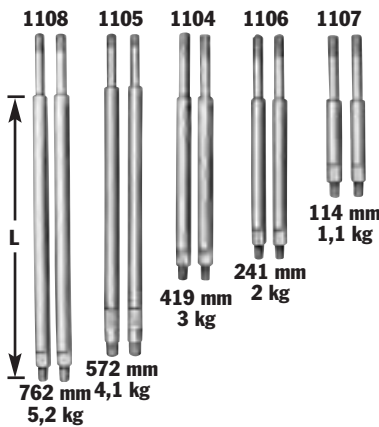

**NOTE:** L = leg length: 114; 241; 419; 572 and 762 mm subtract 124 mm from leg length to determine reach when using leg end caps.

**Selection and capacity rating** – Each Push-Puller's specified tonnage "capacity" is determined using its standard legs in tension. Using longer legs, or a setup in which the legs are in compression, will reduce the "capacity". Always select the largest "capacity" puller and the shortest legs that will fit the job.

**Power Twin® cylinder** – This unique center-hole cylinder powers each Push-Puller®. Puller screw runs right between the twin spring cylinder. A basic head allows you to change from a tapped hole to a plain hole by merely changing the head insert.

### 17½ ton capacity Push-Puller® –

**No. PPH17** – Push-Puller® with RT172 center-hole Power Twin® cylinder, cylinder half coupler, P55 pump, 9767 1,8 m. hose, 9798 hose half coupler, 419 mm legs, 24827 leg ends, 1"-8 x 508 mm lg. adjusting screw and adjusting crank. Wt., 26,8 kg.

**No. PPH17R** – Same as above, but without P55pump, 9767 1,8 m. hose and 9798 hose half coupler. Wt., 18,2 kg.

**No. 1062** – Puller only. (Cylinder, pump, hose, coupler, screw and crank not included.) Wt., 9,1 kg.

### USE WITH:

Bearing pulling attachments: **Nos. 1124 and 1130.**

Pulley pulling attachment: **No. 679.**

Internal pulling attachment: **No. 1154.**

Legs: **Nos. 1104, 1105, 1106, 1107 and 1108 -**

Pair of legs for 17½-ton "capacity" Push-Puller®.

- Can apply a hydraulic pushing or pulling force, depending on how the puller is set up.
- Each unit includes perfectly matched hydraulic components that can be detached from the Push-Puller® for other tasks requiring dependable Power Team power; assuring maximum return on your investment.
- Optional leg kits adapt your Push-Puller® to extra long or extra short reach.
- A wide variety of threaded adapters, bearing pulling attachments and internal pulling attachments can be used in combination with our Push-Pullers®.



### ASSEMBLING THE TOOL TO APPLY PUSHING OR PULLING FORCE:

1. Determine if you want the tool's forcing screw to push or pull.
2. To exert pushing force, the forcing nut is installed beneath the cross block, as shown on left.
3. To cause the forcing screw to pull, the forcing nut is placed on top of the cross block.
4. The sliding plates must always be placed on the opposite side of the cross block from the forcing nut.

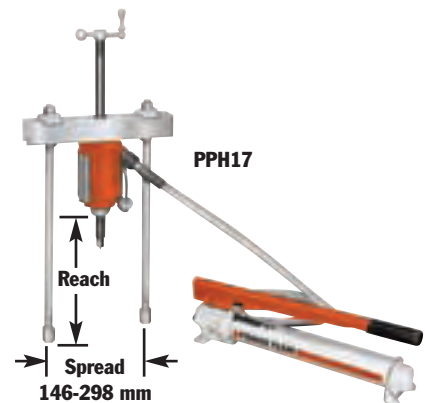
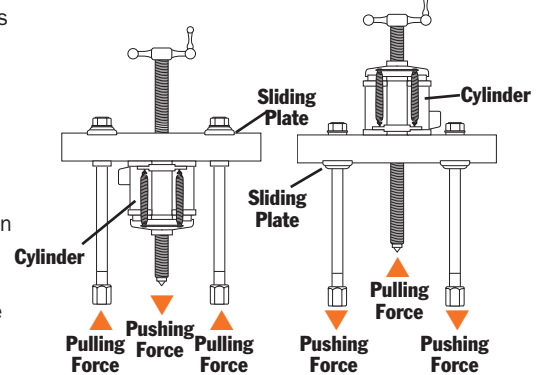

**Leg Ends** – Upper leg ends are threaded ¾"-16. Lower leg ends are threaded ¾"-18 x 25 mm lg.

**30 ton capacity Push-Puller® -**

**No. PPH30** – Push-Puller® with RT302 center-hole Power Twin® cylinder, cylinder half coupler, P55 pump, 9767 1,8 m. hose, 9798 hose half coupler, 457 mm legs, 28390 leg ends, 1<sup>1</sup>/<sub>4</sub>"-7 x 610 mm lg. adjusting screw and adjusting crank. Wt., 46,3 kg.

**No. PPH30R** – Same as above, but without P55 pump, 9767 1,8 m hose and 9798 hose half coupler. Wt., 37,2 kg.

**No. 1070** – Puller only. (Cylinder, pump, hose, coupler, screw and crank not included.) Wt., 19,1 kg.

**USE WITH:**

Bearing pulling attachments. **No. 680** (Use two 8012 adapters to connect to puller.)

Pulley pulling attachment: **No. 679.**

Internal pulling attachment: **No. 1166.**

Legs: **Nos. 1109, 1110 and 1111** - Pair of legs for 30 ton "capacity" Push-Puller®.

**50 ton capacity Push-Puller® -**

**No. PPH50** – Push-Puller® with RT503 center-hole Power Twin® cylinder, cylinder half coupler, P55 pump, 9767 1,8 m hose, 9798 hose half coupler, 610 mm legs, 1<sup>5</sup>/<sub>8</sub>"-5<sup>1</sup>/<sub>2</sub> x 722 mm lg. adjusting screw and adjusting crank. Wt., 91,3 kg.

**No. PPH50R** – Same as above, but without P55 pump, 9767 1,8 m hose and 9798 hose half coupler. Wt., 82,2 kg.

**No. 1076** – Puller only. (Cylinder, pump, hose, coupler, screw and crank not included.) Wt., 48,1 kg.

**USE WITH:**

Bearing pulling attachments: **Nos. 1128 and 1129.**

Legs: **Nos. 1112 and 1113** - Pair of legs for 50 ton "capacity" Push-Puller®.

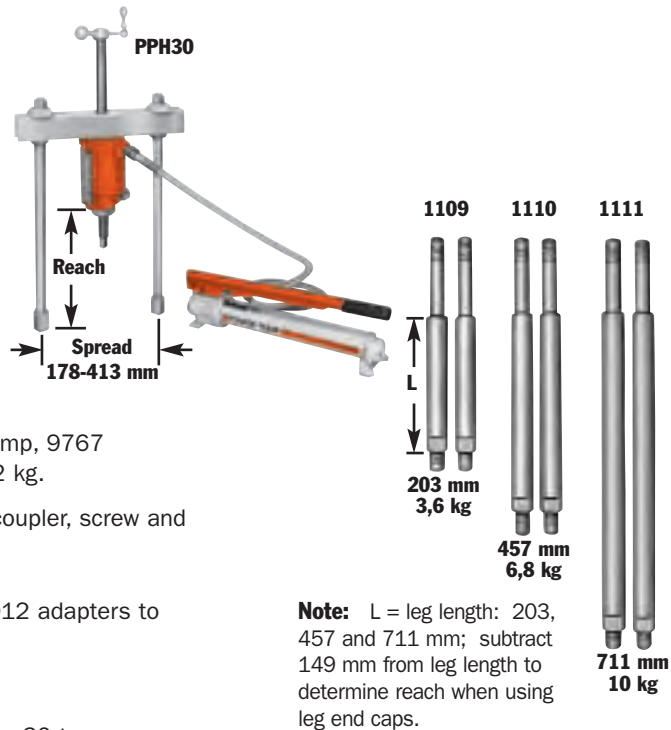

**Leg ends** are threaded 1"-14 x 32 mm lg.

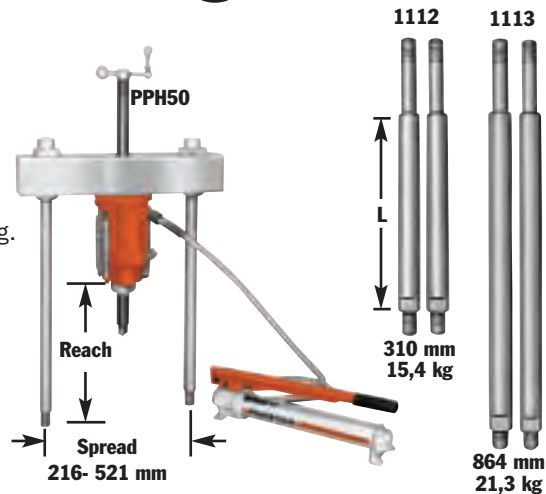

**Leg ends** are threaded 1<sup>1</sup>/<sub>4</sub>"-12 x 44,5 mm lg.

