

- Full off-center pressing at full rated capacity across width of upper frame without buckling or bending.
- Maximum "daylight" is 1.067 x 914 mm, making positioning of even bulky work pieces easy.
- Height of press bed is easily adjusted with winch; friction brake prevents bed from dropping and handle from spinning upon release.
- Presses with single-acting cylinder offer choice of 2-speed hand operated, electric/hydraulic, or air/hydraulic pump. Models with double-acting cylinder have an electric/hydraulic pump.
- Press models equipped with remote control enable operator to view work from all sides with fingertip control of cylinder piston travel.
- Press can be used horizontally for special applications with user-supplied support legs.

Press H FRAME

55 Ton Presses



Hydraulic gauge and hydraulic fittings are included with presses.



No. SF50 – Straightening fixtures for use with 55-ton shop or 80-ton Roll-Bed® presses (2 ea.). Wt., 47,2 kg. **Not part of press, order separately.**

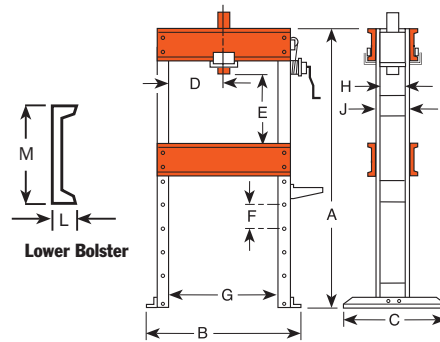

CE

SHOP EQUIPMENT

DIMENSIONS

A (mm)	B (mm)	C (mm)	D* (mm)	E (mm)	F (mm)	G (mm)	H (mm)	J (mm)	L (mm)	M (mm)	Floor Space (mm)
1.829	1.232	914	83-832	152-1.067	152	914	171	203	76	305	1.232 x 914

*Lateral head movement

ORDERING INFORMATION

Cap. (tons)†	Type of Cylinder Used	Stroke (mm)	Cylinder Model	Order No.	Speed (mm/min.)†††	Type Pump	Valve Type	Pump‡ Model	Prod.Wt. (kg)	
55	Single-Acting	159	C556C	SPA556	114	12,7	Air	2-Way Foot	PA6	318
55	Single-Acting	159	C556C	SPM556	5,8 mm/ stroke	0,4 mm/ stroke	Hand Release	Load- Release	P159	323
55	Single-Acting	337	C5513C	SPM5513	18,9 mm/ stroke	0,7 mm/ stroke	Hand	2-Way	P460	435
55	Single-Acting	159	C556C	SPE556	551	38	Elec.	2-Way††	PE172-E220	333
55	Single-Acting	337	C5513C	SPE5513	551	38	Elec.	2-Way††	PE172-E220	444
55	Single-Acting	337	C5513C	SPE5513S	620	48	Elec.	3-Way†	PE172S-E220	478
55	Double-Acting	333	RD5513	SPE5513D	551	38	Elec.	4-Way	PE174-E220	450
55	Double-Acting	333	RD5513	SPE5513DS	1.679	137	Elec.	4-Way†	PE554S-E220	505

* Frame is shipped assembled.

† Solenoid valve with 24 volt remote control hand switch.

†† Holds pressure with motor shut off. Also has an automatic dump setting. Furnished with a 3,1 m remote motor control.

††† Typical performance based on 7 bar and 700 bar pump specifications. Actual speeds may vary with operating conditions.

‡ Pump standard with press. Other Power Team pumps can be substituted. dBA at idle and 700 bar: PE172—67/81; measured at 0,9 m distance, all sides.