

H Frame Presses

100 Ton Presses

SHOP EQUIPMENT



No. SF150 – Straightening fixtures for use with 100-ton shop press and 100-, 150-, and 200-ton RollBed® presses (2 ea.). Wt., 89 kg. **Not part of press, order separately.**

- Cylinder workhead glides across upper frame on rollers, locks in place for off-center pressing jobs. May be used horizontally for special pressing applications with user-supplied supports.
- Press bed is raised and lowered by winch which locks in place for insertion of bed retaining pins. Upper bolster can be lowered 203 mm for convenient positioning on repetitive jobs.
- Generous "daylight" of 1.067 x 1.270 mm accommodates bulky work pieces, uprights are placed for easy side entry of bars or shafts for straightening or bending.
- Choice of single- or double-acting cylinder. Hydraulic pump options include: 2-speed hand pump with large 7,6 l reservoir, PE172 electric/hydraulic pump or "PQ" series "Quiet" electric/hydraulic pump with low noise level.



SPE10013DS
Hydraulic gauge and hydraulic fittings are included with presses.

PUMP ELECTRICAL SPECIFICATIONS

PE17 Series – 0,37 KW, 220 volt, 50 cycle, single phase. Also available in 115 volt, 60 cycle, remove suffix "-220" to order no.
PQ120 Series – 2,24 kW, 380 V, 50 Hz, three phase.

CE

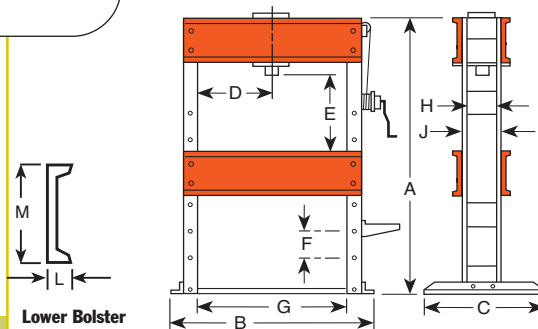

DIMENSIONS

A (mm)	B (mm)	C (mm)	D* (mm)	E (mm)	F (mm)	G (mm)	H (mm)	J (mm)	L (mm)	M (mm)	Floor Space (mm)
1.962	1.626	914	178-1.092	51-1.067	203	1.270	203	254	86	381	914 x 1.988

*Lateral head movement

ORDERING INFORMATION

Cap. (tons)†	Type of Cyl. Used	Stroke (mm)	Cylinder Model	Order No.	Speed (mm/min.)†† Advance	Pressing	Type Pump	Valve Type	Pump‡ Model	Prod. Wt. (kg)
100	Single-Acting	260	C10010C	SPM10010	9,0 mm/ stroke	0,3 mm/ stroke	Hand	3-way	P460	769
100	Single-Acting	260	C10010C	SPE10010	889	74	Elec.	3-way	PE552-E220	813
100	Single-Acting	260	C10010C	SPE10010R	292	20	Elec.	2-way	PE172-E220	766
100	Double-Acting	333	RD10013	SPE10013DS	889	147	Elec.	4-way*	PQ1204SE380	854

† Frame is shipped assembled. *Solenoid valve with 24 volt remote control hand switch.

†† Typical performance based on 7 bar and 700 bar pump specifications. Actual speeds may vary under operating conditions.

‡ Pump standard with press. Other Power Team pumps can be substituted.

dBA at idle and 700 bar: PE172—67/81; PQ120—73/78. Measured at 0,9 m distance, all sides.