

H Frame Presses

150-200 Ton Presses

- Standing 2,3 m tall, these giants handle the really big jobs. May be used horizontally for special pressing applications with user-supplied supports.
- Workhead has wide horizontal travel; rugged press frame withstands load of rated capacity across full width of frame.
- Winch mechanism provides easy positioning of press bed, locks in place for insertion of retaining pins. Upper bolster can be lowered 279 mm for convenient positioning on repetitive jobs.
- Uprights are placed for easy side entry of bars or shafts for straightening or bending.
- Fast cylinder approach is provided by PQ1204S "Quiet" electric/hydraulic pump. Has remote control hand switch, enabling operator to view work from all sides with fingertip control of cylinder piston travel.



Hydraulic gauge and hydraulic fittings are included with presses.

CE

PUMP ELECTRICAL SPECIFICATIONS

PQ120 Series – 2,24 KW, 380 volt, 50 cycle, three phase.

SHOP EQUIPMENT

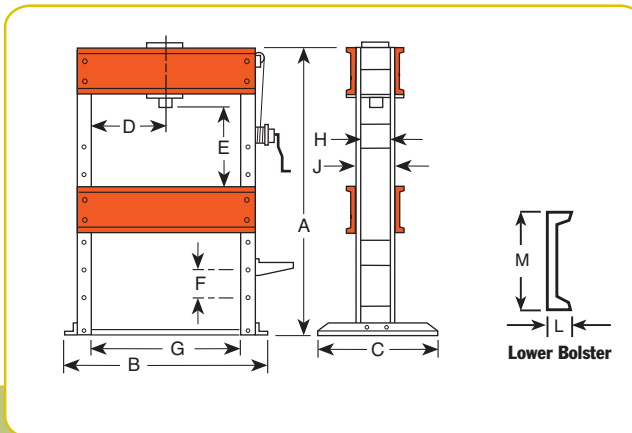

DIMENSIONS

A (mm)	B (mm)	C (mm)	D* (mm)	E (mm)	F (mm)	G (mm)	H (mm)	J (mm)	L (mm)	M (mm)	Floor Space (mm)
2.286	1.803	1,118	279-991	228-1.111	279	1.270	318	381	105	457	1.117 x 1.803

*Lateral head movement

ORDERING INFORMATION

Capacity (tons)†	Type of Cylinder Used	Stroke (mm)	Cylinder Model	Order No.	Speed (mm/min.)†† Advance Pressing	Type Pump	Valve Type	Pump Model***	Prod. Wt. (kg)
150	Double-Acting	333	RD15013	SPE15013DS	610 99	Electric	4-way**	PQ1204S-E380	1.366
200	Double-Acting	333	RD20013	SPE20013DS	457 74	Electric	4-way**	PQ1204S-E380	1.484

† Frame is shipped assembled.

†† Typical performance based on 7 bar and 700 bar pump specifications. Actual speeds may vary under operating conditions.

** Solenoid valve with 24 volt remote control hand switch.

*** Pump standard with press. Other Power Team pumps can be substituted. dBA at idle and 700 bar: 73/78, measured at 0,9 m foot distance, all sides.

PRESS ACCESSORIES

Page 134-135